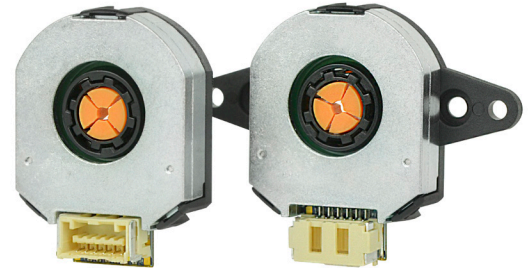

SERIES: AMT23 | **DESCRIPTION:** MODULAR ABSOLUTE ENCODER

FEATURES

- patented capacitive ASIC technology
- low power consumption
- 12 or 14-bit absolute position
- single ended 3-wire Synchronous Serial Interface
- checksum bits for error detection
- configuration and firmware updates via AMT Viewpoint™ software
- digitally settable zero position
- compact modular package with locking hub for ease of installation
- radial and axial cable connections
- -40 ~ 105°C operating temperature

ELECTRICAL

| parameter | conditions/description | min | typ | max | units |
|----------------------------|------------------------|-----|-----|-----|-------|
| power supply | VDD | 3.8 | 5 | 5.5 | V |
| start-up time ¹ | | | 200 | | ms |
| current consumption | with unloaded output | | 16 | | mA |
| input low level | | | | 0.8 | V |
| input high level | | 2.0 | | 5.5 | V |
| output low level | | | | 0.4 | V |
| output high level | | | 3.3 | | V |

Note: 1. Encoder must be stationary during start-up.

ABSOLUTE POSITION CHARACTERISTICS

| parameter | conditions/description | min | typ | max | units |
|-------------------------------|-------------------------------------|-----|-----------|-----|----------|
| resolution | 12 or 14-bit | | | | |
| accuracy | | | 0.2 | | degrees |
| absolute zero position | configurable via AMT Viewpoint™ GUI | | | | |
| absolute position update rate | 12-bit 14-bit | | 25 100 | | μs μs |

MECHANICAL

| parameter | conditions/description | min | typ | max | units |
|-----------------------|--|-----|---------------|----------------|------------|
| motor shaft length | | 9 | | | mm |
| motor shaft tolerance | | | NOM +0/-0.015 | | mm |
| weight | | | 15.7 | | g |
| axial play | | | | ±0.3 | mm |
| rotational speed | 12-bit position resolution 14-bit position resolution | | | 8,000 4,000 | RPM RPM |

ENVIRONMENTAL

| parameter | conditions/description | min | typ | max | units |
|-----------------------|--|-----|-----|-----|-------|
| operating temperature | | -40 | | 105 | °C |
| humidity | non-condensing | | | 85 | % |
| vibration | 10~500 Hz, 5 minute sweep, 2 hours on each XYZ | | | 5 | G |
| shock | 3 pulses, 6 ms, 3 on each XYZ | | | 200 | G |
| RoHS | yes | | | | |

SERIAL INTERFACE

| parameter | conditions/description | min | typ | max | units |
|-----------|---|-----|-----|-----|-------|
| protocol | single ended 3-wire Synchronous Serial Interface ² | | | | |
| data rate | | | 1 | 2 | MHz |
| T_{CLK} | data shifted to output buffer | | | 500 | ns |
| T_{DOV} | time before data is valid | | | 250 | ns |
| T_{CS} | time between reads | 1 | | | µs |

Notes: 2. All SSI signals are single ended. This interface uses a chip select signal for initiating position reads.

Figure 1
Timing Waveform

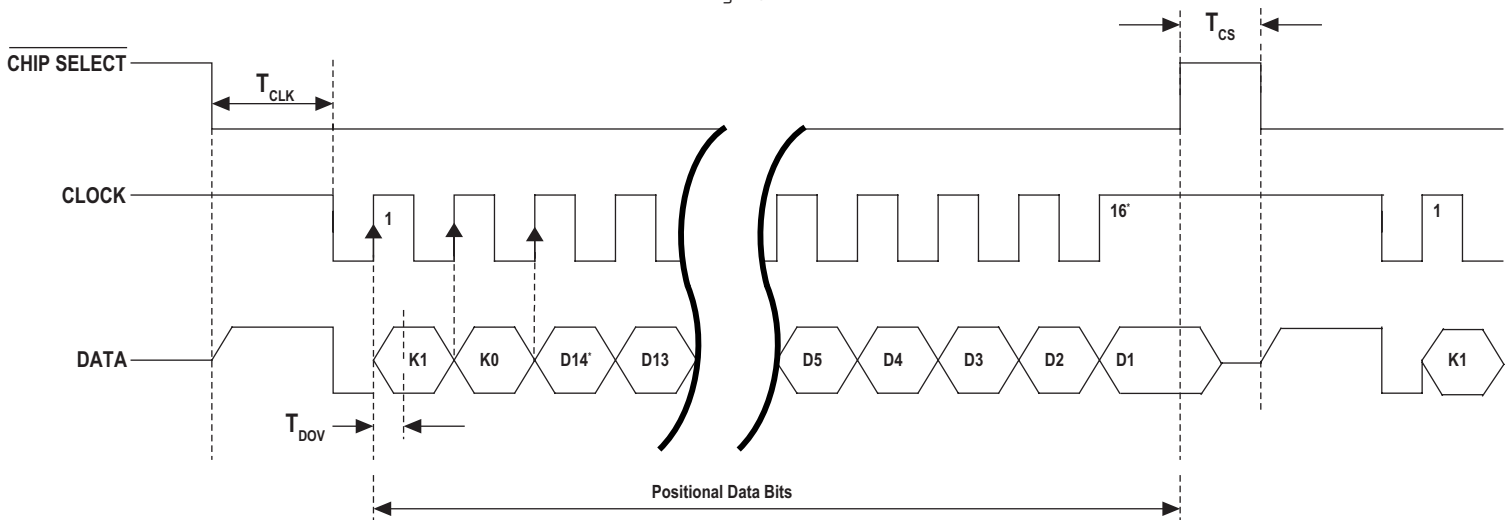

Notes: *For 12-bit applications the clock can be stopped after 14 cycles, or if you clock the full 16 times L0 and L1 are always 0. Because the low two bits are 0, 12-bit data would need to be right-shifted two bits. The checkbit calculation remains the same and unaffected.

Values K1 and K0 in the response are checkbits. The checkbits are odd parity over the odd and even bits in the position response shown in the equation below. The checkbits are not part of the position, but are used to verify its validity. The lower 14 bits are the encoder position.

Example:

Full response: 0x61AB

14-bit position: 0x21AB (8619 decimal)

Checkbit Formula

Odd: $K1 = !(H5 \wedge H3 \wedge H1 \wedge L7 \wedge L5 \wedge L3 \wedge L1)$

Even: $K0 = !(H4 \wedge H2 \wedge H0 \wedge L6 \wedge L4 \wedge L2 \wedge L0)$

From the above response 0x61AB:

Odd: $0 = !(1 \wedge 0 \wedge 0 \wedge 1 \wedge 1 \wedge 1) = \text{correct}$

Even: $1 = !(0 \wedge 0 \wedge 1 \wedge 0 \wedge 0 \wedge 0) = \text{correct}$

PART NUMBER KEY

For customers that prefer a specific AMT23 configuration, please reference the custom configuration key below.

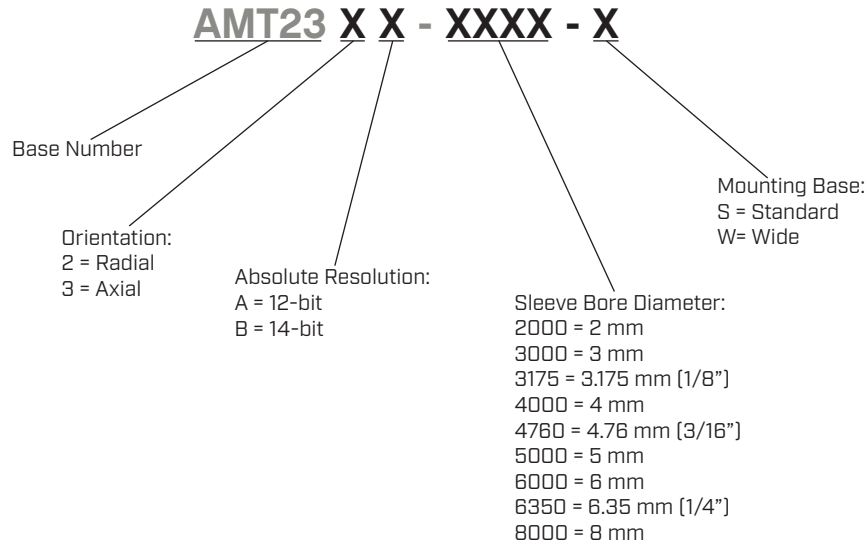

AMT23-V KITS

In order to provide maximum flexibility for our customers, the AMT23 series is provided in kit form standard. This allows the user to implement the encoder into a range of applications using one sku#, reducing engineering and inventory costs.

ORDERING GUIDE

AMT23XX-V

Orientation:
2 = Radial
3 = Axial

Absolute Resolution:
A = 12-bit
B = 14-bit

| SLEEVES | | | | | | | | |
|----------------|--------|--------------------|------|--------------------|-------|-----|-------------------|------|
| | | | | | | | | |
| 2mm | 3mm | 1/8 inch (3.175mm) | 4mm | 3/16 inch (4.76mm) | 5mm | 6mm | 1/4 inch (6.35mm) | 8mm |
| Light Sky Blue | Orange | Purple | Gray | Yellow | Green | Red | Snow | Blue |

| BASE | WIDE BASE | TOP COVER | SHAFT ADAPTER | TOOL A | TOOL C |
|------|-----------|-----------|---------------|--------|--------|
| | | | | | |

ENCODER INTERFACE

| PINOUT CONNECTOR | |
|------------------|-------------|
| # | Function |
| 1 | +5 V |
| 2 | DATA |
| 3 | CLOCK |
| 4 | GND |
| 5 ¹ | MODE |
| 6 | CHIP SELECT |

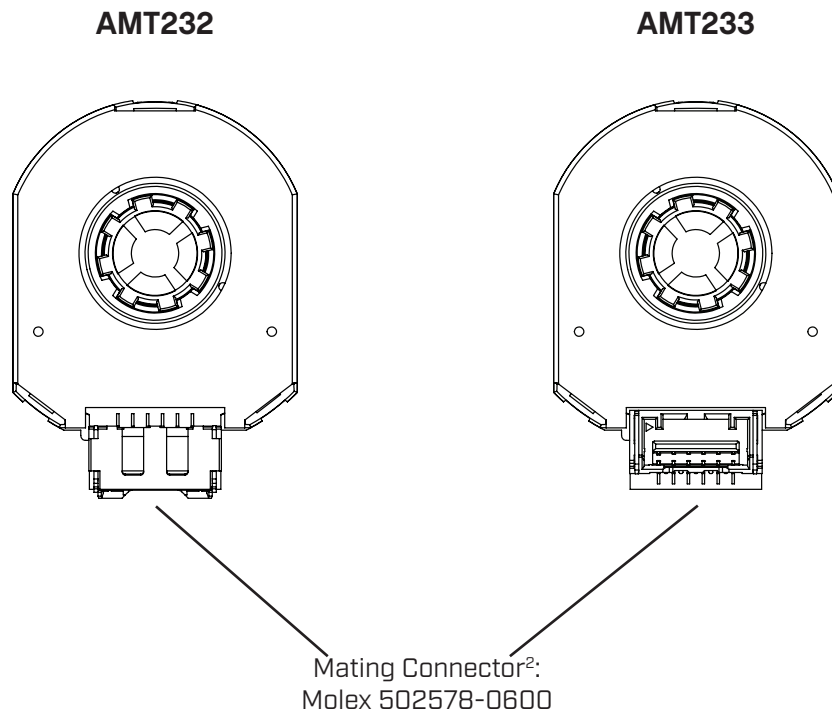

Notes:

1. Mode pin is used by AMT Viewpoint™ for configuring the encoder and should be left open during normal operation.
2. Compatible with prototype cable AMT-06C-1-036 and programming cable AMT-06C-1-036-USB.

MECHANICAL DRAWING

AMT232

units: mm
tolerance: ± 0.1

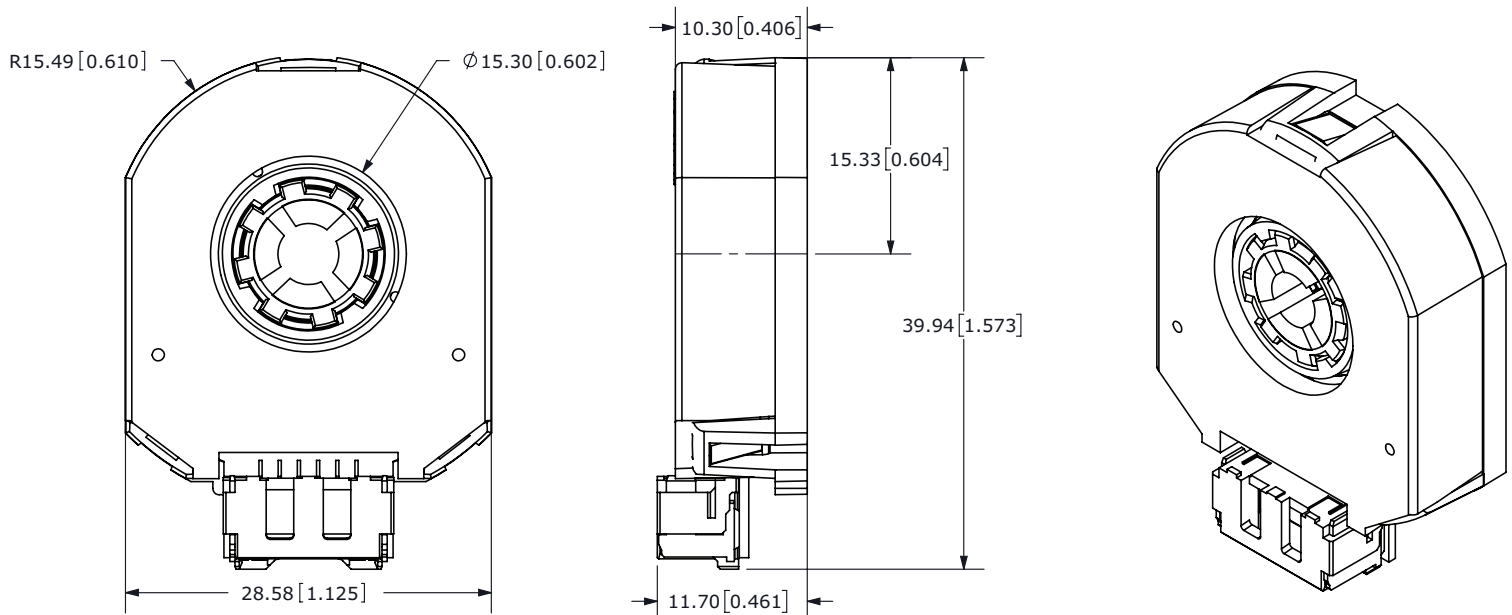

AMT233

units: mm
tolerance: ± 0.1

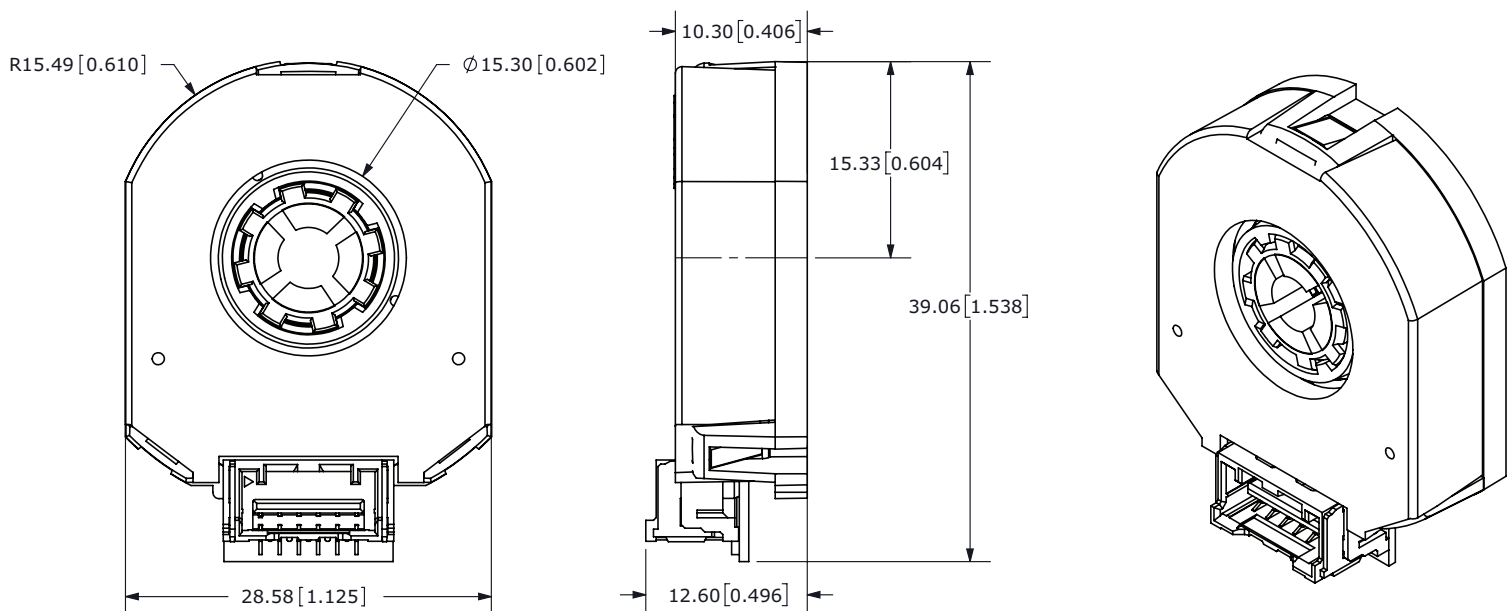

MECHANICAL DRAWING (CONTINUED)

MOUNTING HOLE PATTERNS

STANDARD BASE

units: mm[inch]
tolerance: ±0.1

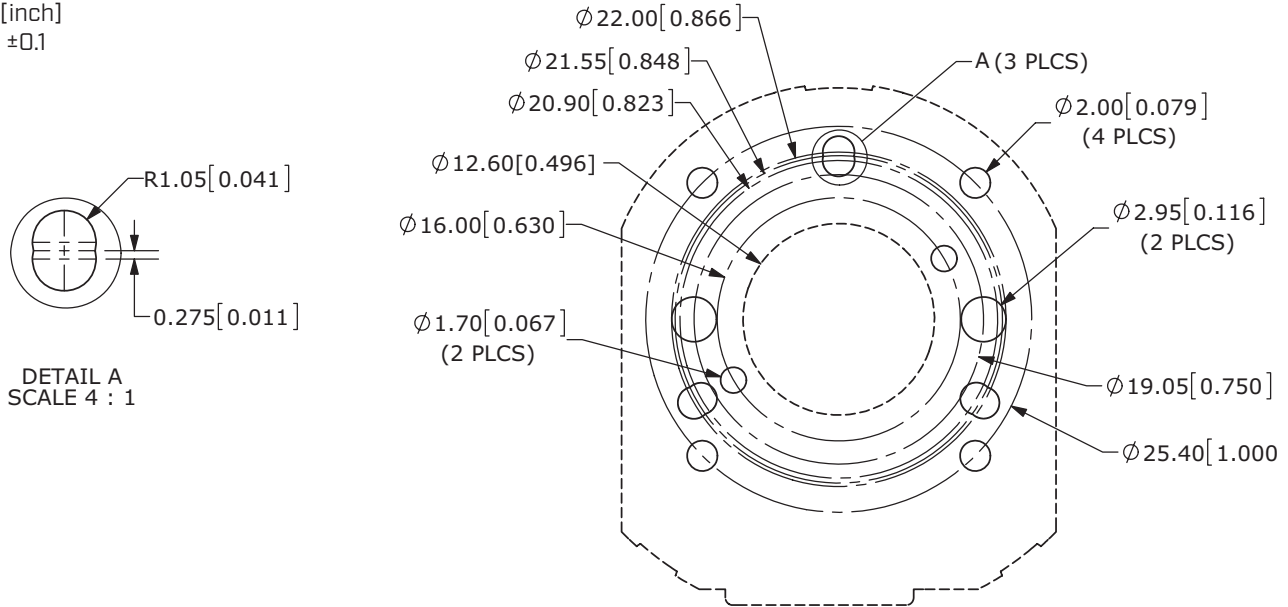

WIDE BASE

units: mm[inch]
tolerance: ±0.1

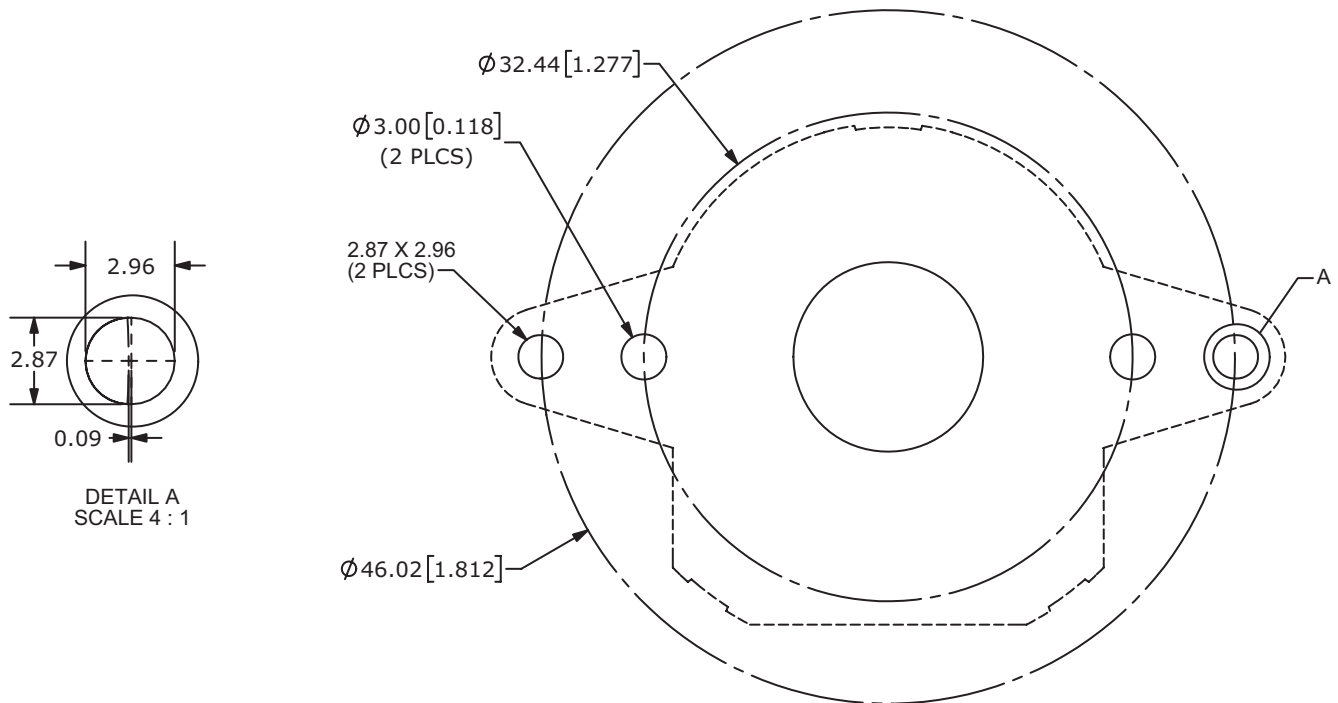

ASSEMBLY PROCEDURE

STEP 1



1. Insert Tool A as a spacer that defines the distance to the mounting surface.
2. Slide appropriate sized Sleeve over shaft all the way down to Tool A.
3. Slide Shaft Adaptor over Sleeve.
4. Use Tool C to press Shaft Adaptor over Sleeve [ensure Shaft Adaptor and Tool C spline alignment] until flush with Tool A.

STEP 2

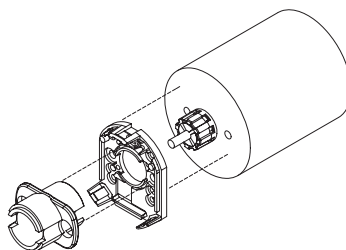

1. Remove Tools A and C.
2. Place Base on motor, with Tool C used as a centering tool.

STEP 3

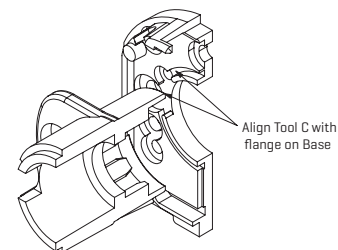

1. Align Tool C with flange on Base.
2. Slide Base and Tool C onto motor, centering onto the Shaft Adaptor.

STEP 4



1. Fasten the Base on the motor (Tool C may need to be rotated to allow for some mounting configurations).
2. Remove Tool C.

STEP 5

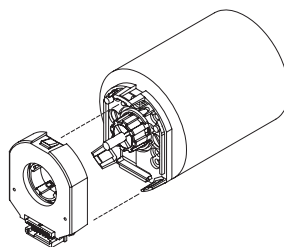

1. Snap the Top Cover onto the Base, carefully observing that the teeth of the Shaft Adaptor align with the grooves in the hub. *

* We recommend no more than three cycles of mounting and removal of the AMT top cover base. Multiple cycles of mounting and removing the top cover can cause base fatigue over time and affect encoder performance.

STEP 6

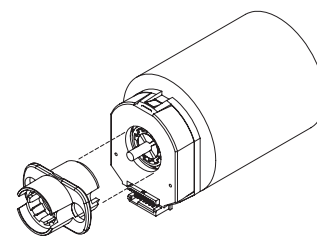

1. Make sure the snaps are fully engaged by pressing on the Hub with the reverse side of Tool C.
2. When assembly is finished, the Shaft Adaptor, Sleeve and Rotor Hub should all be flush with the Motor Shaft rotating freely.

REVISION HISTORY

| rev. | description | date |
|------|---|------------|
| 1.0 | initial release | 01/23/2018 |
| 1.01 | added serial interface details | 05/08/2018 |
| 1.02 | updated current consumption value | 07/17/2019 |
| 1.03 | added start-up time details | 08/12/2019 |
| 1.04 | brand update | 11/21/2019 |
| 1.05 | added motor shaft tolerance details, updated start-up details | 09/10/2021 |
| 1.06 | logo, datasheet style update | 08/05/2022 |

The revision history provided is for informational purposes only and is believed to be accurate.



CUI Devices offers a one (1) year limited warranty. Complete warranty information is listed on our website.

CUI Devices reserves the right to make changes to the product at any time without notice. Information provided by CUI Devices is believed to be accurate and reliable. However, no responsibility is assumed by CUI Devices for its use, nor for any infringements of patents or other rights of third parties which may result from its use.

CUI Devices products are not authorized or warranted for use as critical components in equipment that requires an extremely high level of reliability. A critical component is any component of a life support device or system whose failure to perform can be reasonably expected to cause the failure of the life support device or system, or to affect its safety or effectiveness.

cuidevices.com